

Model 90-110-150

Triple Reduction Planetary Gear Reducer

Flange Mount

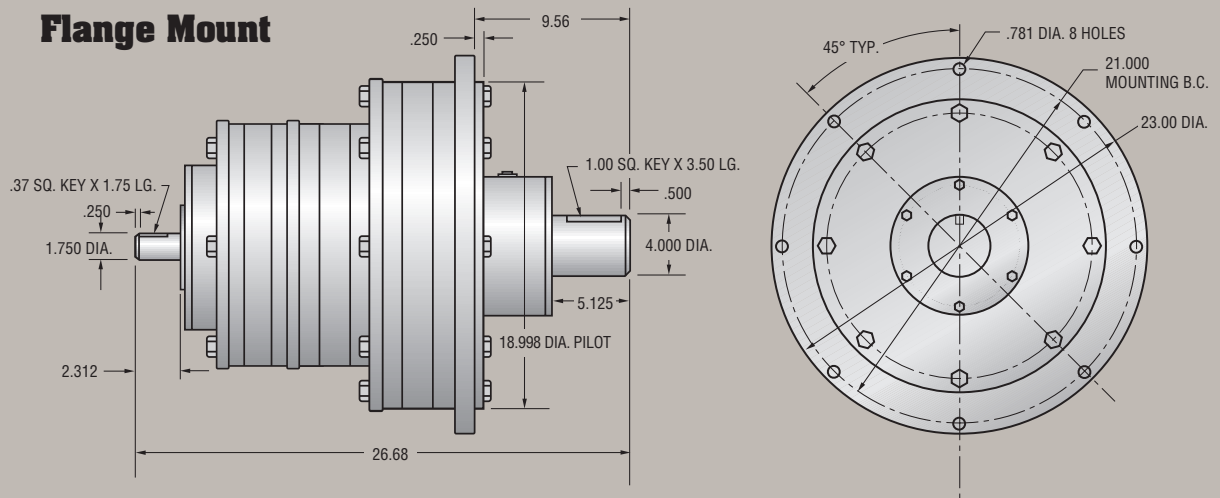

Foot Mount

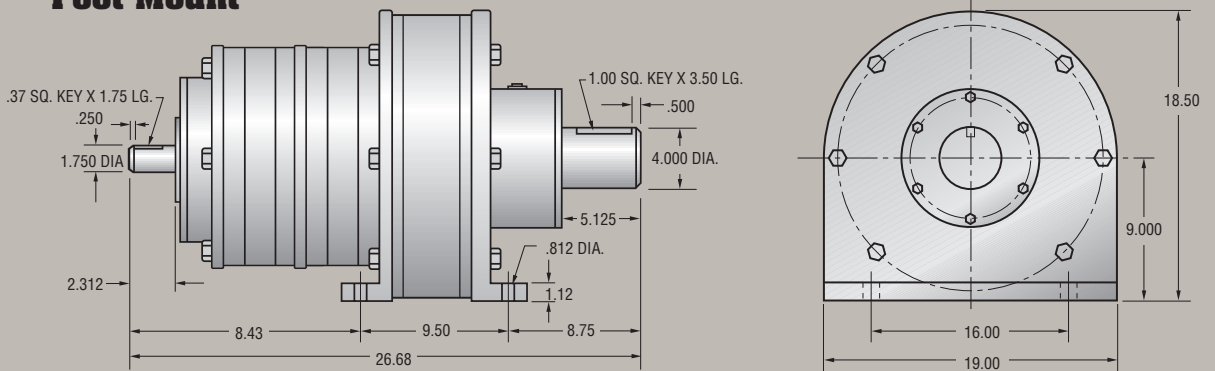

Flange or Foot Mount w/SAE or NEMA Input

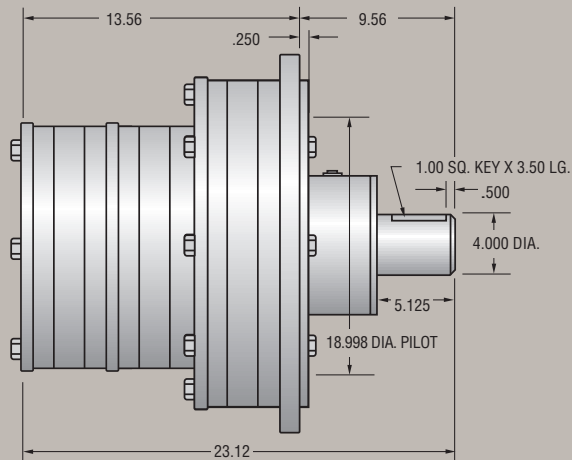

NEMA Electric Motor Direct Mount

"C" face direct couple of motor to speed reducer. No need for coupling or special motor mounts.

SAE Hydraulic Motor Direct Mount

2 bolt or 4 bolt direct couple of hydraulic motor to speed reducer. No need for coupling or special motor mounts.



Byrne
**Gear Corporation
of America**

- Planetary speed reducers
- High-speed increasers
- Custom design geared products

"The Problem Solver"

Model 90-110-150

Triple Reduction Planetary Gear Reducer

Planetary Assembly	Ratios	OUTPUT HORSE POWER RATINGS (Adjusted for Thermal Efficiencies)						
		INPUT R.P.M.						
		100	580	720	870	1170	1430	1750
EEE	27.00	11.07	37.91	44.10	50.35	61.95	71.29	82.12
EEA	31.50	9.04	30.93	35.99	41.08	50.55	58.18	67.01
EEB	36.00	8.09	27.69	32.22	36.78	45.26	52.08	59.99
EAA	36.75	8.11	27.77	32.31	36.88	45.38	52.23	60.16
CEE	39.00	8.56	29.30	34.09	38.92	47.89	55.11	63.48
BEA	42.00	7.39	25.29	29.42	33.59	41.33	47.57	54.79
AAA	42.87	7.28	24.93	29.00	33.11	40.74	46.88	54.00
ECA	45.50	6.99	23.91	27.82	31.76	39.08	44.97	51.80
EBB	48.00	6.61	22.64	26.34	30.07	37.00	42.58	49.05
AAB	49.00	6.52	22.32	25.96	29.64	36.47	41.97	48.35
ECB	52.00	6.25	21.41	24.91	28.43	34.99	40.26	46.38
CAA	53.08	6.27	21.47	24.97	28.51	35.08	40.37	46.50
DEE	54.00	6.82	23.33	27.15	30.99	38.13	43.89	50.55
BBA	56.00	6.04	20.68	24.06	27.46	33.79	38.89	44.79
CCE	56.33	6.62	22.65	26.36	30.09	37.02	42.61	49.07
CBA	60.67	5.71	19.55	22.75	25.97	31.95	36.77	42.35
DEA	63.00	5.56	19.01	22.15	25.29	31.12	35.81	41.25
BBB	64.00	5.41	18.51	21.54	24.59	30.25	34.82	40.10
CCA	65.72	5.40	18.49	21.59	24.55	30.21	34.77	40.05
CBB	69.33	5.11	17.50	20.36	23.25	28.60	32.92	37.92
DEB	72.00	4.98	17.05	19.83	22.64	28.86	32.06	36.93
DAA	73.50	4.99	17.09	19.89	22.70	27.94	32.15	37.03
CCB	75.11	4.78	16.55	19.25	21.98	27.05	31.13	35.85
DCE	78.00	5.27	18.04	20.99	23.96	29.48	33.93	39.08
CCC	81.37	3.01	11.61	13.51	15.42	18.98	21.84	25.15
DBA	84.00	4.55	15.57	18.11	20.68	25.44	29.28	33.33
DCA	91.00	4.30	14.72	17.13	19.55	24.06	27.68	31.89
DBB	96.00	3.75	13.94	16.21	18.51	22.78	26.21	30.19
DCB	104.00	3.47	13.18	15.33	17.50	21.54	24.78	28.55
DDE	108.00	4.20	14.36	16.71	19.08	23.47	27.01	31.12
DCC	112.66	2.18	9.25	10.76	12.28	15.11	17.39	20.03
DDA	126.00	3.42	11.72	13.64	15.57	19.16	22.04	25.39
DDB	144.00	2.51	10.49	12.21	13.94	17.15	19.74	22.73
DDC	156.00	1.58	7.36	8.57	9.78	12.03	13.85	15.95
DDD	216.00	1.35	5.63	6.55	7.48	9.21	10.59	12.20

Ratings based upon uniform steady and moderate shock loading. See load factor chart for details.

OUTPUT SHAFT RADIAL (overhung) LOAD CAPACITIES (at output r.p.m.)								
R.P.M.	10	20	30	50	100	200	300	500
Radial Capacity (lbs.)	20,000	16,000	14,000	12,000	10,000	9,500	8,000	6,500

OUTPUT SHAFT THRUST LOAD CAPACITIES (at output r.p.m.)								
R.P.M.	10	20	30	50	100	200	300	500
Radial Capacity (lbs.)	36,209	28,997	26,051	22,344	18,155	14,750	13,059	11,200

OUTPUT SHAFT MAXIMUM CONTINUOUS TORQUE CAPACITY: 100,780 lb./inches
OUTPUT SHAFT INTERMITTENT TORQUE CAPACITY: 201,560 lb./inches
WEIGHT: 700 lbs.
RATING SYSTEM: All Ratings Based Upon American Gear Manufacturers' Association Standards



Byrne

GEAR CORPORATION OF AMERICA

301 Byrne Gear Drive
P. O. Box 1789
Mansfield, Ohio 44901
Telephone: (419) 522-GEAR(4327)
Fax: (419) 525-2386
E-mail: byrne@byrnegroup.com
Visit our web site at: www.byrnegroup.com

Part of The Byrne Group

Copyright © Byrne Gear Corporation of America
Printed in U.S.A. 697